

SUPERIOR CLEANING



**Ergonomic
design**



**Low water
consumption**



**Large
opening**



**Low electricity
consumption**

FEATURES

- ✓ Rigid mounted, normal spin, 100 G
- ✓ Stainless steel top panel, anthracite grey front and side panels
- ✓ Stainless steel drum and tub
- ✓ Basic control – easy to use microprocessor
- ✓ Patented soap hopper
- ✓ High capacity water inlets (LS280)
- ✓ Large drain valve (Ø76mm)
- ✓ Easy access to all vital parts from the front
- ✓ Large door opening for easy loading and unloading



OPTIONS

- Professional control – fully programmable
- Coin-operated timer (CPS)
- Stainless steel front and side panels
- USB plug (on the back panel)
- Liquid Soap Print – liquid soap connection
- Liquid soap pumps
- Water recovery kit
- Steam heating version
- High capacity water inlets (LS180 – LS240)
- 175 G-factor execution
- 7 mm drum holes (LS180 - LS240)
- Automatic door opening in case of power failure



SUPERIOR CLEANING

DIMENSIONS & SPECIFICATIONS

INNER DRUM	Max. capacity 1:9	kg 31
	Capacity 1:10	kg 28
	Volume	litres 280
	Diameter	mm 750
DRUM SPEED	Wash speed	rpm 42
	Extraction speed	rpm 490 (100G) - 645 (175G)
	G-factor speed	100 (optional 175)
HEATING	Electricity (standard)	kW 21,9
	Steam	bar 1-8
	Hot water	°C 90
	Sound pressure level	dB (A) <65
	Water valves connection	BSP ¾"
	Water pressure	kPa 100-800
	Rec. water pressure	kPa 300-500
	Water inlet	litres/min. 20
	Drain valve (outer Ø)	mm 76
	Flow amount with drain valve	litres/min. 210
	Steam valve connection	BSP ½"
	Steam pressure	kPa 100-800
DIMENSIONS	Size HxWxD	mm 1410x890x1135
	Net weight	kg 290
TRANSPORT DATA	Bruto weight	kg 305
	Packing dimensions HxWxD	mm 1550x925x1190

Standard = Standard version.

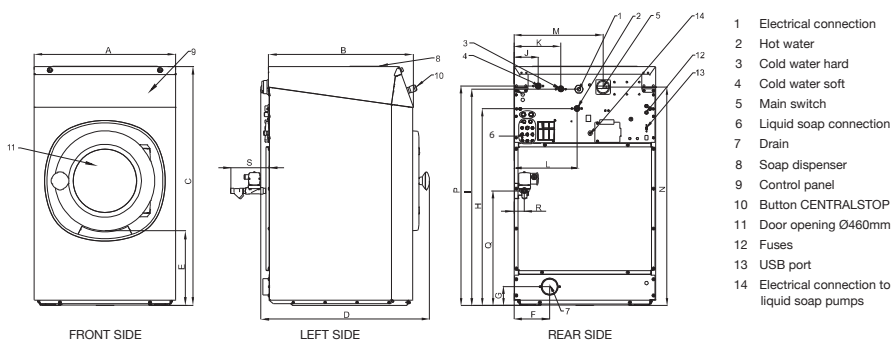

	A	B	C	D	E	F	G	H	I	J	K	L	M	N	P	Q	R	S
LS180	890	915	1410	815	465	280	130	1212	1297	113	218	303	625	1270	1317	528	54	120
LS240	890	1060	1410	960	465	280	130	1212	1297	113	218	303	625	1270	1317	528	54	120
LS280	890	1135	1410	1035	465	280	130	1212	1297	113	218	303	625	1270	1317	528	54	120
	width	depth	height															

